

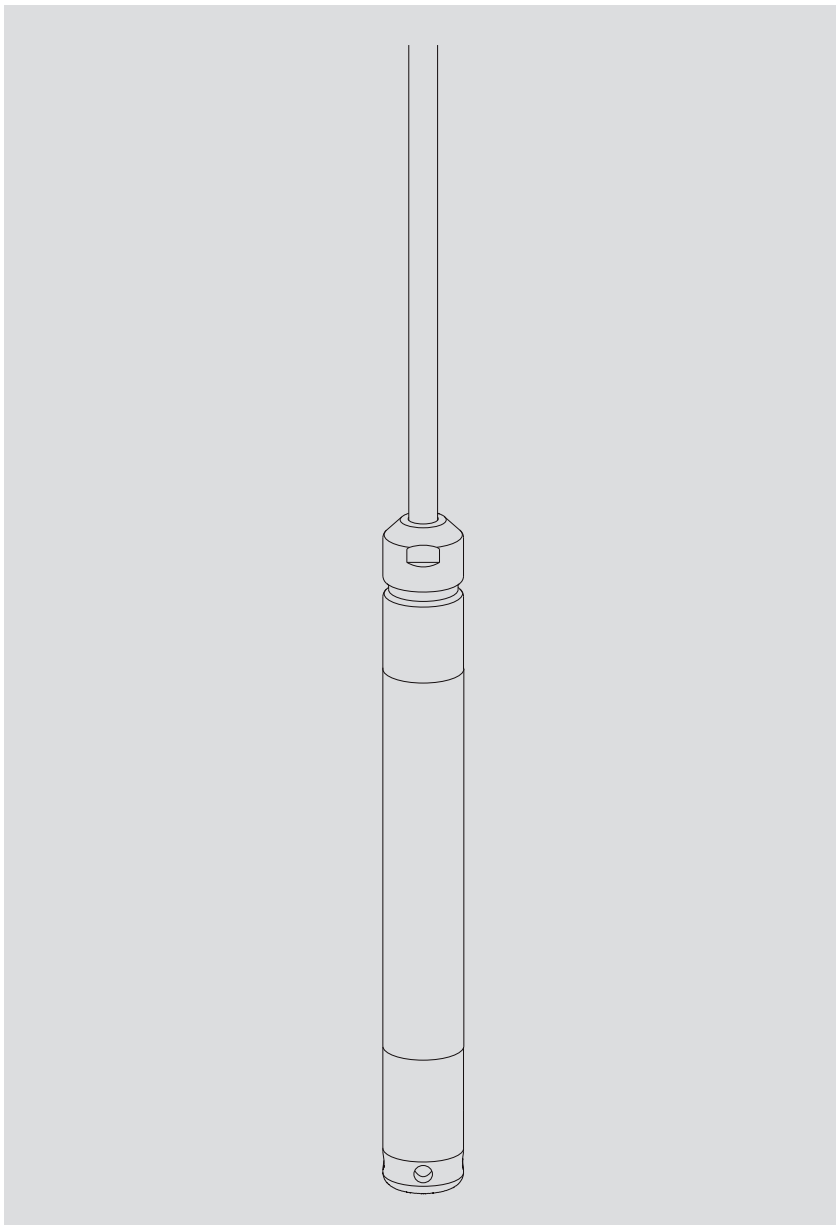

Operating instructions
Pressure Probe OTT PLS



English

We reserve the right to make technical changes and improvements without notice.

Table of contents

1 Scope of Supply	4
2 Order Numbers	4
3 Basic safety instructions	5
4 Introduction	6
5 Installing the pressure probe	8
5.1 Installation type A: fixing the pressure probe into a protective device	8
5.2 Installation type B: hanging pressure probe	9
5.3 Connecting humidity absorbing system	10
5.4 Wire assignment of the pressure probe cable	10
5.5 Connecting the OTT PLS to any datalogger using an SDI-12 interface	11
5.6 Connecting the OTT PLS to any datalogger using a 4 ... 20 mA interface	11
5.7 Determining the maximum load resistance at the 4 ... 20 mA interface	11
5.8 Note on using the 4 ... 20 mA interface	12
5.9 Note on using the RS-485 interface	12
6 SDI-12 Commands and Responses	13
6.1 Standard commands	13
6.2 Advanced SDI-12 commands	15
7 Carrying out maintenance work	20
8 Searching for disruptions/troubleshooting	21
9 Repair	22
10 Note about the disposal of old units	22
11 Technical Data	23
Appendix A – Connecting the OTT PLS to the OTT netDL or OTT DuoSens datalogger using an SDI-12 or RS-485 interface	25
Appendix B – Connecting the OTT PLS to the OTT netDL or OTT DuoSens datalogger using a 4 ... 20 mA interface	28
Appendix C – Installing the OTT FAD 5 humidity absorbing system	30
Appendix D – Installing the OTT FAD 4PF humidity absorbing system	32
Appendix E – Note on Declaration of conformity	33

1 Scope of supply

- ▶ **OTT PLS**
 - 1 Pressure probe with a ceramic, capacitive, relative pressure measuring cell and shielded pressure probe cable with pressure compensation capillary and Kevlar core for length stabilization. Pre-fabricated cable end with transport protection against moisture.
 - 1 Set of operating instructions
 - 1 Factory acceptance test certificate (FAT)

2 Order numbers

- ▶ **OTT PLS**
 - OTT PLS pressure probe** 63.037.001.9.0
 - Version with 4 ... 20 mA interface
 - Version with SDI-12 interface
 - Version with RS-485 interface (SDI-12 protocol)
 - Required order information
 - Measuring range: 0 ... 4 m;
0 ... 10 m;
0 ... 20 m;
0 ... 40 m;
0 ... 100 m
 - Cable length: 1 ... 200 m (with SDI-12 interface: 1 ... 100 m)
- ▶ **Accessories**
 - Humidity absorbing system OTT FAD 4PF** 63.025.021.4.2
 - desiccant cartridge in clear container with connection tube for pressure compensation capillary
 - Humidity absorbing system OTT FAD 5** 63.037.025.3.2
 - connecting box (pressure probe cable ↔ connection cable datalogger/voltage supply) with desiccant cartridge
 - Desiccant cartridge** 97.100.066.4.5
 - replacement cartridge in transport container
 - Cable attachment** 96.140.173.9.5
 - Connection cable** 97.000.040.9.5
 - twisted pair construction; LiYY
 - PVC, black
 - 2 x 2 x 0.75 mm²
 - unshielded
 - Connection cable** 97.000.039.9.5
 - twisted pair construction; FD CP (TP)
 - PVC, gray
 - 2 x 2 x 0.5 mm²
 - shielded

3 Basic safety information



- ▶ Read these operating instructions before using the OTT PLS for the first time! Make yourself completely familiar with the installation and operation of the OTT PLS! Retain these operating instructions for later reference.
- ▶ The OTT PLS is used for measuring the water level of ground and surface waters in hydrometry. Only use the OTT PLS as described in these operating instructions!
For further information, → see Chapter 4, "Introduction".
- ▶ Note all the detailed safety information given within the individual work steps. All safety information in these operating instructions are identified with the warning symbol shown here.
- ▶ Ensure the electrical, mechanical, and climatic specifications listed in the technical data are adhered to.
For further information → see Chapter 11, "Technical data".
- ▶ Do not make any changes or retrofits to the OTT PLS. If changes or retrofits are made, all guarantee claims are voided.
- ▶ Have a faulty OTT PLS inspected and repaired by our repair center. On no account carry out repairs yourself!
For further information → see Chapter 9, "Repair".
- ▶ Dispose of the OTT PLS properly after taking out of service. On no account put the OTT PLS into the normal household waste.
For further information → see Chapter 10, "Note about the disposal of old units".

4 Introduction

The OTT PLS pressure probe is used for precisely measuring the water level of ground and surface waters. The pressure probe uses the hydrostatic pressure of the water column above a relative pressure measuring cell to do so. A pressure compensation capillary in the pressure probe cable gives the measuring cell the current ambient air pressure as a reference. Erroneous measurement results due to atmospheric air pressure fluctuations are thus eliminated.

The OTT PLS can be supplied with various measuring ranges:

- ▶ 0 ... 4 m water column (0 ... 0.4 bar)
- ▶ 0 ... 10 m water column (0 ... 1 bar)
- ▶ 0 ... 20 m water column (0 ... 2 bar)
- ▶ 0 ... 40 m water column (0 ... 4 bar)
- ▶ 0 ... 100 m water column (0 ... 10 bar)

Furthermore, the pressure probe can be supplied with either an analog or digital interface:

- ▶ 4 ... 20 mA interface (with additional RS-485 interface (SDI-12 protocol) for configuring the 4 ... 20 mA interface*)
- ▶ SDI-12 interface
- ▶ RS-485 interface (SDI-12 protocol)

The pressure probe with the SDI-12/RS-485 interface can be configured via the SDI-12 transparent mode of a datalogger. For example, a reference value or offset value can be entered when starting up the device. With the 4 ... 20 mA version, it is possible to scale the measured value output to a smaller measuring range using the additional RS-485 interface available (SDI-12 protocol).

A particular feature is that the pressure probe measures the water temperature as well as the hydrostatic pressure of the water column and thus yields highly precise and reproduceable measurement results by compensating the effects of temperature, specific density of the water and the local gravitational acceleration at the specific station. (For this, the specific density and local gravitational acceleration are entered as required during startup.)

At the SDI-12 and RS-485 interfaces, the OTT PLS outputs either the water level (compensated) or the hydrostatic pressure as well as the water temperature: at the 4 ... 20 mA interface, either the water level (compensated) or hydrostatic pressure. Measurement units can be set with SDI-12 commands as m / cm / ft (water level measurement), mbar / psi (pressure measurement) and °C / °F (temperature measurement).

The properties mentioned enable the universal operation of the pressure probe: for example for connection to a datalogger, controlling pen recorders, alarm devices, switching contacts, and, together with a display, for the display of measured values.

A humidity absorbing system for drying the surrounding air that enters the pressure compensation capillary is available as an accessory.

* No parallel operation of the interfaces

Fig. 1: Main layout of a water level station with the OTT PLS pressure probe.

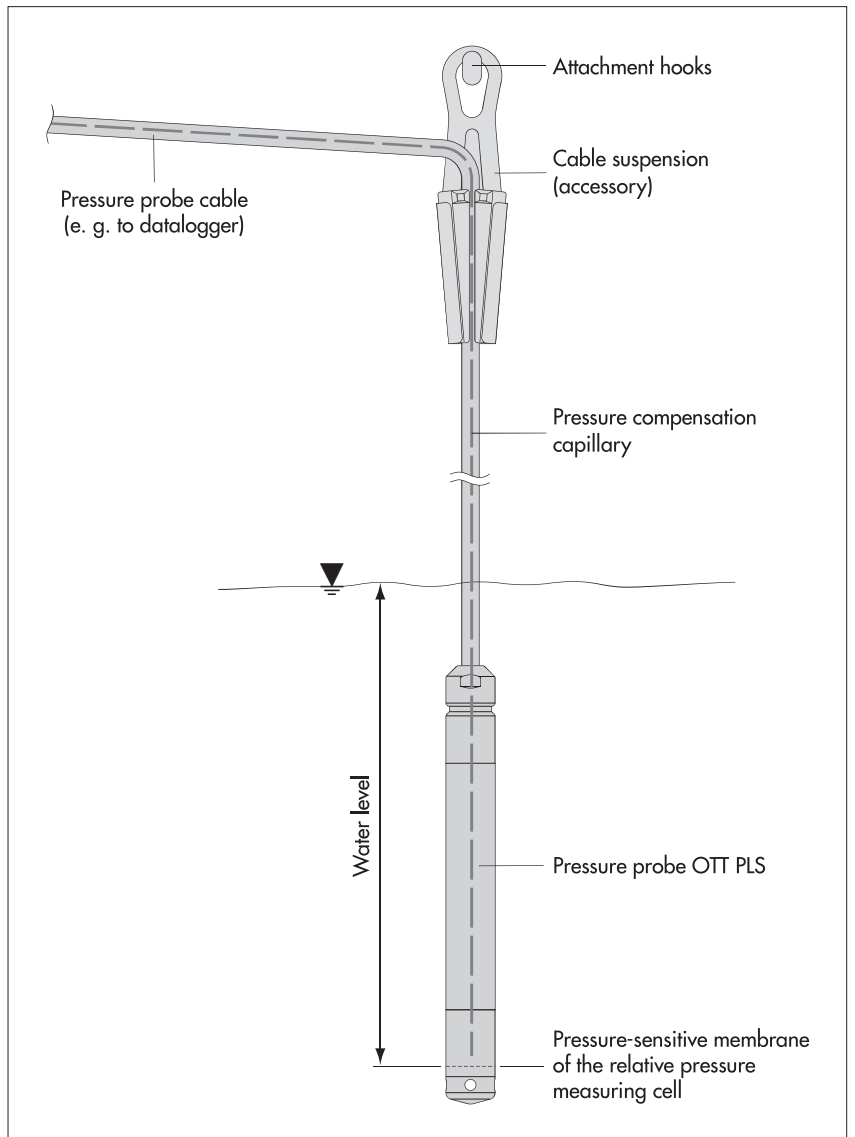

5 Installing the pressure probe

The OTT PLS pressure probe can be used in a variety of ways, for example in observation wells and boreholes from 1" diameter, in shafts, open waterways, and in waterways that do not always hold water.

Caution

We do not recommend installing the pressure probe in the vicinity of port facilities, industrial waste water discharges or areas with heavy chemical contamination. The pressure probe is constructed from high-quality stainless steel and plastic. However, depending on the mounting location, damaging corrosion can arise. For more information on the materials used, see Chapter 11 "Technical data".

The pressure probe can be installed in two ways:

- ▶ fixed in an individual protective device, built on location, or
- ▶ hung on the pressure probe cable.

Caution

No moisture should be allowed to enter the pressure compensation capillary of the pressure probe cable during installation! Very high air humidity can also lead to the formation of water droplets in the pressure compensation capillary due to temperature changes. These inevitably lead to unusable measurement results! As a result, ensure the transport protection is left on the cable end during the whole time it is being laid!

5.1 Installation type A: fixing the pressure probe into a protective device

In flowing waters or waterways with a swell, the pressure probe must be fixed. With strong currents ($> 0.5 \dots 1$ m/s) the hydrodynamic influences of the station have to be considered in the installation. Depending on the version and mounting of the individual components, overpressure or negative pressure can arise that can affect the measurement result.

- Determine the minimum and maximum water level at your station (e.g. staff gauge, contact gauge). Use both values to specify the probe position. The following conditions must be fulfilled:
 - position the probe below the minimum water level if possible;
 - difference between max. water level and position of the probe $<$ measuring range of the probe.
- Fix the pressure probe according to your individual requirements in a protective device, as shown in Figure 2, for example.

Note

The fine setting of the probe position is carried out, for example, by entering a reference or offset value (with SDI-12/RS-485 interface) or using a scaling function of the datalogger connected.

Fig. 2: Installation example of the OTT PLS pressure probe in open waterways.

With waterways with currents or swell, a fixing pin is used to securely fasten the probe. Push the fixing pin through the holes in the black protective cap.

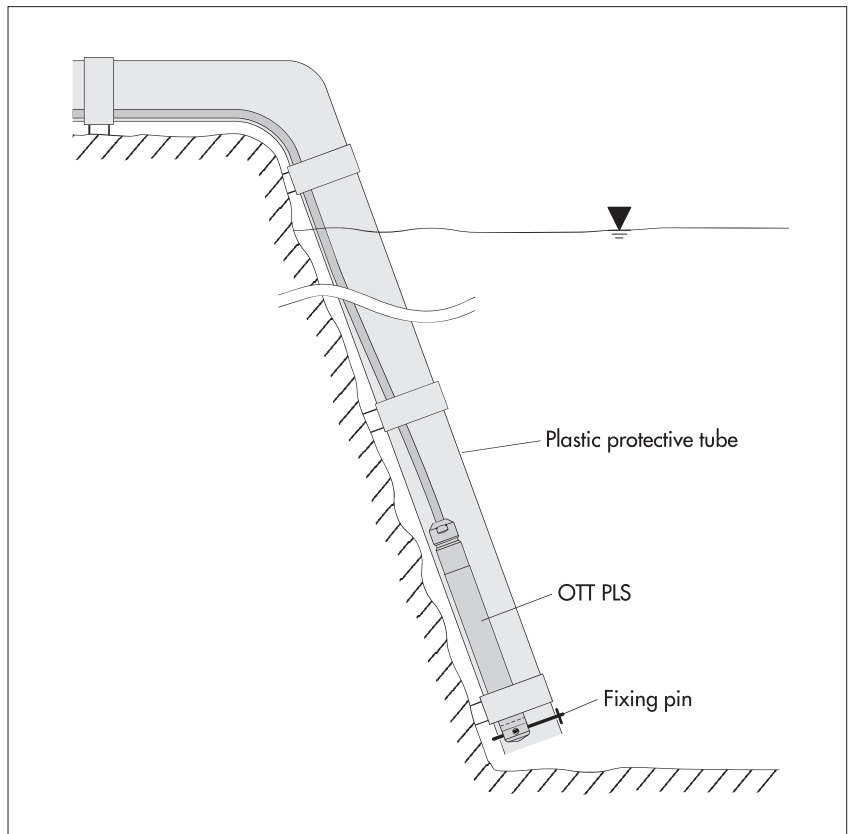

5.2 Installation type B: hanging pressure probe

See also Figure 1.

- Determine the minimum and maximum water level at your station (e.g. staff gauge, contact gauge). Use both values to specify the probe position. The following conditions must be fulfilled:
 - position the probe below the minimum water level if possible;
 - difference between max. water level and position of the probe < measuring range of the probe.
- Fix the cable attachment (accessory) at a suitably sized attachment point.
- Carefully lower the pressure probe on the pressure probe cable to the specified depth. There are markings on the cable every 0.25 m to assist orientation.
- Lay the pressure probe cable in the opened clamping jaws of the cable attachment as shown in Figure 1 and secure the pressure probe cable by pushing the clamping jaws together. The mechanical longitudinal stability required is provided by Kevlar fibers inside the pressure probe cable. **Caution:** maximum hanging depth: 50 m. (greater depths on request).

Notes

- ▶ The fine setting of the probe position is carried out, for example, by entering a reference or offset value (with SDI-12/RS-485 interface) or using a scaling function of the datalogger connected. It is thus sufficient in many applications to position the probe approximately.
- ▶ If the pressure probe cable ends in the immediate vicinity of the cable attachment: fix the Kevlar fibers at a suitable point in addition!

5.3 Connecting humidity absorbing system

A humidity absorbing system must be installed for drying the surrounding air that enters the pressure compensation capillary of the pressure probe cable! See Appendix C and D.

Caution

Humidity entering the pressure compensation capillary leads to unusable measurement results!

5.4 Wire assignment of the pressure probe cable

Fig. 3: Wire assignment of the OTT PLS pressure probe cable.

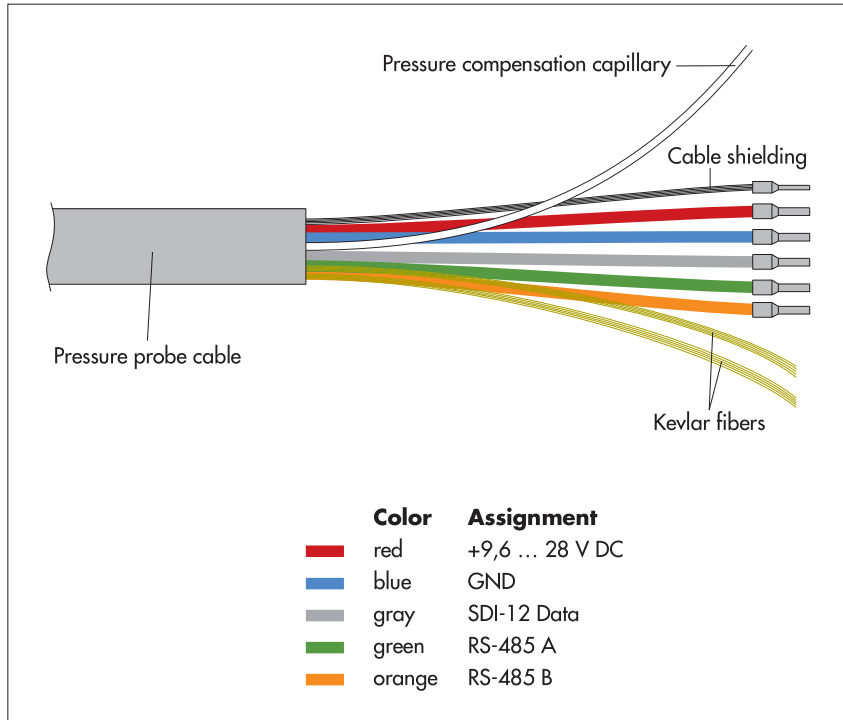

Caution

The factory assembled pressure probe cable should only be shortened with a suitable wire stripping tool! Danger of damaging the cable!
Recommendation: Store excess cable in loops if necessary!

If necessary, the pressure probe cable can be lengthened. For this purpose, use a suitable junction box (e.g. OTT FAD 5). This should also be large enough to hold the humidity absorbing system. The maximum cable length for the RS-485 interface and the 4 ... 20 mA interface is 1,000 m. Recommended cable type for the RS-485 interface: shielded, twisted-pair cable. The wires intended for the power supply can be twisted pair, but do not have to be. Recommended cable type for the 4 ... 20 mA interface: unshielded, low-voltage cable. If the additional RS-485 interface (configuring the 4 ... 20 mA interface) is also to be fed to the datalogger, a twisted pair cable is also necessary in this case.

Suitable wire sizes

- ▶ Up to 500 m cable length: 2 x 2 x 0.5 mm² (41 Ohm/1,000 m)
- ▶ 500 to 1,000 m cable length: 2 x 2 x 0.75 mm² (27 Ohm/1,000 m)

5.5 Connecting the OTT PLS to any datalogger using an SDI-12 interface

- Connect the OTT PLS to an SDI-12 input of the datalogger. Follow the datalogger handbook when doing this. Refer to Figure 4 for the wire assignments of the OTT PLS. Wires used: red, blue, and gray. The maximum length of the cable is 100 m.
- To achieve better protection against overloads, you can optionally connect the cable shielding to a grounding point/equipotential busbar.

Fig. 4: Wires used with an SDI-12 interface.

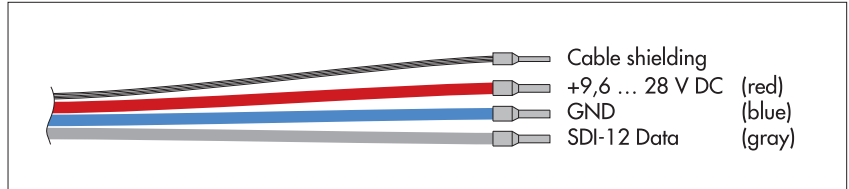

Note

The standard supply voltage (12 Volt line) in an SDI-12 bus is 12 Volts and the maximum is 16 Volts. Take this into account if other sensors are available in the SDI-12 bus in addition to the OTT PLS sensor.

The SDI-12 commands and responses used with the OTT PLS can be found in Chapter 6, SDI-12-Commands and Responses.

5.6 Connecting the OTT PLS to any datalogger using a 4 ... 20 mA interface

- Connect the OTT PLS to a 4 ... 20 mA input of the datalogger. Follow the datalogger handbook when doing this. Refer to Figure 5 for the connection assignments of the OTT PLS. Wires used: red and blue.
Maximum cable length: dependent on the level of the supply voltage and size of the burden (load resistor). Ensure that the ohmic resistance of the pressure probe cable together with any burden present does not exceed the maximum permitted load resistance (see Chapter 5.7). The upper limit for the cable length is 1,000 m in all cases.
- To achieve better protection against overloads, you can optionally connect the cable shielding to a grounding point/equipotential busbar.

Fig. 5: Wires used with a 4 ... 20 mA interface.

If the OTT PLS is to be configured via the RS-485 interface, the green and orange wires are required in addition.

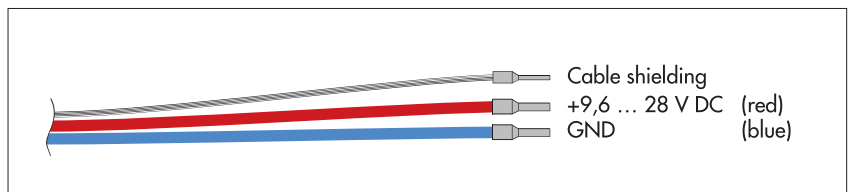

5.7 Determining the maximum load resistance at the 4 ... 20 mA interface

The load resistance (burden + ohmic resistance of the connection cable) connected to the OTT PLS must not exceed a specific maximum value. This value depends on the level of the supply voltage of the OTT PLS. If the load resistance is greater, the loop current* can no longer be evaluated. Smaller load resistances are allowed.

* Due to the imposed (controlled) current by the OTT PLS of the 4 ... 20 mA interface ($\hat{=}$ measured value)

- See the following diagram for the maximum load resistance applicable to your power supply. Alternatively, the maximum load resistance can be calculated according to the formula:

$$R_{\text{load (max)}} = (U_{\text{supply}} - 8.5 \text{ V}) / 0.025 \text{ A}$$

Example: Power supply 24 Volt → max. load resistance 620 Ohm.

The OTT PLS delivers a loop current corresponding to the measured value for a load resistance of up to 620 Ohm.

- Dimension the connected electrical circuit accordingly. Check the input resistance of the connected peripheral device for this purpose.

Fig. 6: Diagram to determine the maximum load resistance as a function of the power supply.

Minimum power supply: 9.6 V
Maximum power supply: 28 V

Burden tolerance: 0.1 %/15 ppm.
(Burden = load resistor).

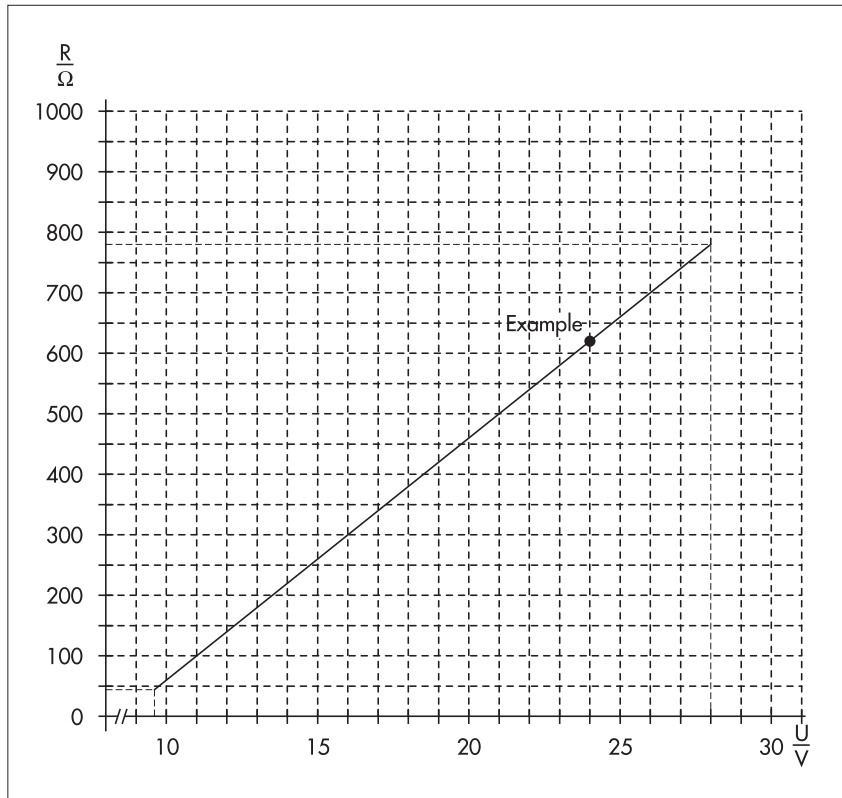

5.8 Note on using the 4 ... 20 mA interface

- Behavior when switching on the 4 ... 20 mA interface
After providing the supply voltage, it takes approx. 7 seconds for the loop current to take on the value proportional to the water level. (In the first 7 seconds, the loop current is between 3 and 4 mA.) Afterwards, the pressure probe updates the loop current every 2 seconds.
- Loop current when configuring the 4 ... 20 mA interface
If there is a communication via the RS-485 interface, the loop current is higher than the appropriate level for the measured value by several mA. After the end of the communication, it takes approx. 250 ms until the loop current takes on the appropriate value again.

5.9 Note on using the RS-485 interface

The RS-485 interface is designed and tested for use with OTT dataloggers. In this case, the transmission protocol via the physical RS-485 interface is the SDI-12 protocol. Connecting OTT PLS via the RS-485 interface to the OTT netDL/OTT DuoSens → see Appendix A, Method B.

OTT provides no guarantee of functionality if you connect the OTT PLS to the data logger of a third-party manufacturer via the RS-485 interface!

6 SDI-12 Commands and Responses

6.1 Standard commands

All SDI-12 standard commands are implemented in the OTT PLS. The following SDI-12 standard commands are relevant for the operation of the OTT PLS:

Command	Response	Description
a!	a<CR><LF>	Confirmation active a – sensor address; factory setting = 0
aI!	a13ccccccmmmmmm vvvxxxx<CR><LF>	Send identification a – Sensor address 13 – SDI-12 protocol version ccccccc – manufacturer identification (company name) mmmmmm – Sensor identification vvv – Sensor version (firmware) xxxxxx – Serial number Answer OTT PLS = 0130TTHACHPLS000100123456
aAb!	b<CR><LF>	Change sensor address a – old sensor address b – new sensor address
?!	a<CR><LF>	Query sensor address a – sensor address
aM!	atttn<CR><LF> and after 1 ... 60 second(s) ¹⁾ a<CR><LF>	Starting the measurement a – Sensor address ttt – Time in seconds until the sensor has determined the measurement result Answer OTT PLS = 001 ... 060 ¹⁾ n – Number of measured values Answer OTT PLS = 2 or 4 ²⁾ a<CR><LF> – Service request
aD0!	a<value1><value2>... ...<value3><value4><CR><LF>	Send data a – sensor address <value1> – average ²⁾ level/pressure value measured value formats: m → pbbbb.eee cm → pbbbbbbbb ft → pbbbb.ee mbar → pbbbb.ee psi → pbbbb.eee <value2> – temperature value measured value formats: °C and °F → pbbb.e <value3> ²⁾ – minimum level/pressure value within the actual measuring interval measured value formats: see above <value4> ²⁾ – maximum level/pressure value within the actual measuring interval measured value formats: see above p – sign (+,-) b – numbers (before the decimal point) Output is without leading zeroes! e – digits after the decimal point
aMC!	atttn<CR><LF> and after 2 seconds a<CR><LF>	Start the measurement and request CRC (Cyclic Redundancy Check). For details see command aM! . The answer to the following aD0! command is extended by a CRC value: a<value1><value2><CRC><CR><LF>

¹⁾ depending to the setting of measuring time (aOXM)

²⁾ if measuring time (aOXM) is ≥ 3 seconds

Command	Response	Description
aC!	attnn<CR><LF>	Start concurrent measurement (simultaneous measurement with multiple sensors on one bus feed). For more details, see command aM!. The number of measured values in the answer to this command is two-digit: nn = 02.
aCC!	attnn<CR><LF>	Start concurrent measurement (simultaneous measurement with multiple sensors on one bus feed) and request CRC (Cyclic Redundancy Check). For more details, see command aM!. The number of measured values in the answer to this command is two-digit: nn = 02. The answer to the following aD0! command is extended by a CRC value: a<value1><value2><CRC><CR><LF>
aM1!	attn<CR><LF> and immediately afterwards a<CR><LF>	Query status of the last measurement a – Sensor address ttt – Time in seconds until the sensor has made the result of the system test available Answer OTT PLS = 000 n – Number of measured values Answer OTT PLS = 1 a<CR><LF> – Service request
aD0!	a<value><CR><LF>	Send data (after aM1!, aMC1!, aC1!, aCC1!) a – Sensor address <value> – Status of the last measurement +0 = no hardware defect found +128 = flash memory defective +256 = Watchdog error +512 = memory defective +1024 = pressure cell defective +2048 = D/A converter defective
aMC1!	attn<CR><LF> and immediately afterwards a<CR><LF>	Query the status of the last measurement and request CRC (Cyclic Redundancy Check). For details see command aM1!. The answer to the following aD0! command is extended by a CRC value: a<value><CRC><CR><LF>
aC1!	attnn<CR><LF>	Query the status of the last measurement in concurrent mode (simultaneous measurement with multiple sensors on one bus feed). For more details, see command aM!. The number of measured values in the answer to this command is two-digit: nn = 02.
aCC1!	attnn<CR><LF>	Query the status of the last measurement in concurrent mode (simultaneous measurement with multiple sensors on one bus feed) and request CRC (Cyclic Redundancy Check). For more details, see command aM!. The number of measured values in the answer to this command is two-digit: nn = 02. The answer to the following aD0! command is extended by a CRC value: a<value><CRC><CR><LF>
aV!	attn<CR><LF> and immediately afterwards a<CR><LF>	Carrying out a system test a – Sensor address ttt – Time in seconds until the sensor has made the result of the system test available Answer OTT PLS = 000 n – Number of measured values Answer OTT PLS = 1 a<CR><LF> – Service request

Command	Response	Description
aD0!	a<value><CR><LF>	Send data (after aV!) a – Sensor address <value> – Result of the system test +0 = no hardware defect found +128 = flash memory defective +256 = Watchdog error +512 = memory defective +1024 = pressure cell defective +2048 = D/A converter defective

More information on the SDI-12 standard commands can be found in the document "SDI-12; A Serial-Digital Interface Standard for Microprocessor-Based Sensors, Version 1.3" (see Internet page "www.sdi-12.org").

6.2 Advanced SDI-12 commands

All advanced SDI-12 commands begin with an "O" for OTT. With these commands, it is possible to configure the OTT PLS using the transparent mode of a datalogger.

Command	Response	Description
▶ Setting/reading the level/pressure measurement values		
aOSU<value>!	a<value><CR><LF>	Set unit
aOSU!	a<value><CR><LF>	Read out unit a – Sensor address <value> – Units for level +0 = m; factory setting +1 = cm +2 = ft The level measurement is carried out with compensation for water density, water temperature and local gravitational acceleration. Units for pressure measurement +3 = mbar +4 = psi Pressure measurement is carried out without compensation!
Caution If settings for the parameters "Offset", "Reference value", "Upper limit" or "Lower limit" have been made before changing the unit, they must be reset! There is no automatic conversion of the parameters set!		
▶ Setting/reading the temperature value units		
aOST<value>!	a<value><CR><LF>	Set unit
aOST!	a<value><CR><LF>	Read out unit a – Sensor address <value> – +0 = °C; factory setting +1 = °F

Command	Response
► Set/read local gravitational acceleration	
aOXG<value>!	a<value><CR><LF>
aOXG!	a<value><CR><LF>

Description

Set local gravitational acceleration
 Read out local gravitational acceleration
a – Sensor address
 <value> – **b. eeeee**
b – numbers before the decimal point
c – numbers after the decimal point
 Value range: 9.78036 ... 9.83208 m/s²
 Factory setting = 9.80665 m/s²

The gravitational acceleration at the earth's surface fluctuates between 9.78036 m/s² at the equator and 9.83208 m/s² at the poles. Also, it decreases by 0.003086 m/s² for each kilometer of elevation above sea level.

Formula for the local gravitational acceleration "g" in m/s²:
 $g = 9.780356 (1 + 0.0052885 \sin^2 \alpha - 0.0000059 \sin^2 2\alpha) - 0.003086 h$
 α latitude; h = height above sea level in km

(Source: Jursa, A.S., Ed., Handbook of Geophysics and the Space Environment, 4th ed., Air Force Geophysics Laboratory, 1985, pp. 14-17).

Example

Local gravitational acceleration in Kempten: At a height above sea level of 669 m and a latitude of 47.71°, a local gravitational acceleration of 9.80659 m/s² results.

Note

The OTT PLS is preset to an average value for Germany (Kassel). The measurement deviation caused by gravitational acceleration is ±3 mm in Germany (Flensburg – Oberstdorf). This measurement error is compensated by inputting the local gravitational acceleration.

► Set/read average water density	
aOXR<value>!	a<value><CR><LF>
aOXR!	a<value><CR><LF>

Set medium water density
 Read out medium water density
a – Sensor address
 <value> – **b. eeeee**
b – numbers before the decimal point
a – numbers after the decimal point
 Value range: 0.50000 ... 2.00000 kg/dm³
 Factory setting = 0.99997 kg/dm³ (at 3.98 °C)
 With this command you can set the actual density of the water at your station for level/depth measurement. For example, this is worthwhile at stations with brackish water.

► Set/read depth measurement measuring mode	
aOAA<value>!	a<value><CR><LF>
aOAA!	a<value><CR><LF>

Set measuring mode depth measurement
 Read out measuring mode
a – Sensor address
 <value> – +0 = depth measurement measuring mode deactivated
 +1 = depth measurement measuring mode activated

Caution

If settings for the parameters "Offset", "Reference value", "Upper limit" or "Lower limit" have been made before changing the measuring mode, they must be reset! There is no automatic conversion of the parameters set!

Command	Response	Description
▶ SDI-12-/RS-485 interface – setting/reading offset for level/depth measurement		
aOAB<value>!	a0022<CR><LF> and after 2 seconds a<CR><LF>	Setting the offset value
aOAB!	a<value><CR><LF>	<p>Reading out the offset value</p> <p>a – Sensor address</p> <p><value> – pbbbb.eee</p> <p>p – sign (+,-)</p> <p>b – numbers (before the decimal point)</p> <p>e – numbers after the decimal point</p> <p>a<CR><LF> – Service request</p> <p>Input/output is without leading zeroes. Value range: -9999.999 ... +9999.999 Factory setting = +0.000</p> <p>With this command you can add a linear offset (positive/negative) to a level/depth measurement value. After setting the offset value, the OTT PLS automatically starts a measurement. After receiving the service request, check the measured value with command aD0!. After an unsuccessful entry, the pressure probe replies with a new service request.</p> <p>Caution This command overwrites any set reference value!</p> <p>Example Measured value = +10.040 m Offset = -0.200 m Output = +9.840 m</p> <p>Note If the unit is changed afterwards (aOSU<value>!), rounding errors of ±0.001 are possible.</p>
▶ SDI-12-/RS-485 interface – setting/reading reference value for level/depth measurement		
aOAC<value>!	a0022<CR><LF> and after 2 seconds a<CR><LF>	Setting the reference value
aOAC!	a<value><CR><LF>	<p>Reading out the reference value</p> <p>a – Sensor address</p> <p><value> – pbbbb.eee</p> <p>p – sign (+,-)</p> <p>b – numbers (before the decimal point)</p> <p>e – numbers after the decimal point</p> <p>a<CR><LF> – Service request</p> <p>Input/output is without leading zeroes. Value range: -9999.999 ... +9999.999 Factory setting = +0.000</p> <p>With this command you can establish a reference to a level zero, for example, by entering a reference value for level/depth measurement. After setting the reference value, the OTT PLS automatically starts a measurement. After receiving the service request, check the measured value with command aD0!. After an unsuccessful entry, the pressure probe replies with a new service request.</p>

Command	Response	Description
		<p>Caution This command overwrites any set offset value.</p> <p>Example Measured value = +2.100 m reference value = +1.500 m output = +1.500 m (offset calculated by the OTT PLS and applied to all other measured values = +0.600 m)</p> <p>Note If the unit is changed afterwards (aOSU<value>!), rounding errors of ±0.001 are possible.</p>
▶ Setting/reading the measuring time		
aOXM<value>! aOXM!	a<value><CR><LF> a<value><CR><LF>	<p>Set measuring time Read out measuring time a – Sensor address <value> – bb b – numbers Input/output is without leading zeroes! Value range: 1 ... 60 [s] Factory setting = 2 [s]</p> <p>Note If measuring time is ≥ 3 seconds, <value3> and <value4> appear additionally in the response to an aD0! command. With 1 second measuring time, the response is identical to 2 seconds measuring time.</p>
▶ 4 ... 20 mA interface – setting/reading the lower limit		
aOPA<value>! aOPA!	a<value><CR><LF> a<value><CR><LF>	<p>Setting the lower limit Reading out the lower limit a – Sensor address <value> – pbbbb.eee p – sign (+,-) b – numbers (before the decimal point) e – numbers after the decimal point Input/output is without leading zeroes! Value range: -9999.999 ... +9999.999 Factory setting = +0.000</p> <p>Note If the unit is changed afterwards (aOSU<value>!), rounding errors of ±0.001 are possible.</p>
▶ 4 ... 20 mA interface – setting/reading the upper limit		
aOPB<value>! aOPB!	a<value><CR><LF> a<value><CR><LF>	<p>Setting the upper limit Reading out the upper limit a – Sensor address <value> – pbbbb.eee p – Sign (+,-) b – Numbers (before the decimal point) e – Numbers after the decimal point Input/output is without leading zeroes. Value range: -9999.999 ... +9999.999 Factory setting = +0.000</p> <p>Note If the unit is changed afterwards (aOSU<value>!), rounding errors of ±0.001 are possible.</p>

Using the commands "setting/reading the upper/lower limit" you can scale the measurement output of an OTT PLS to a smaller measuring range. Where you do not require the whole measuring range, this has the advantage that a higher resolution for the 4 ... 20 mA interface can be achieved. Example: A measuring range of 16 mA is available for 5 m water level change (e.g. lower limit = +10,000 m; upper limit = +15,000 m. See Figure 7). At the same time, you can use these commands to apply a linear offset (positive/negative) to the measured values of the 4 ... 20 mA interface.

Fig. 7: Scaling measurement output of the 4 ... 20 mA interface to a smaller measuring range.

Example: OTT PLS with measuring range 0 ... 20 m.

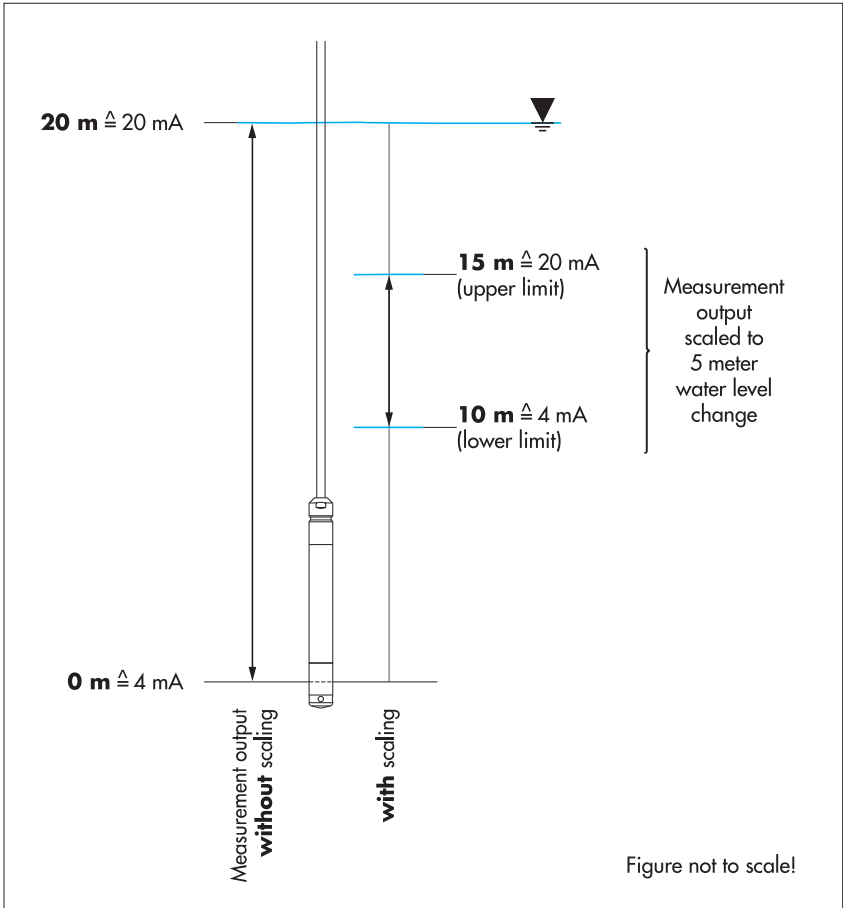

7 Carrying out maintenance work

The high-quality design of the OTT PLS makes regular cleaning work unnecessary. Even a thin build-up of deposits on the measuring cell will not appreciably affect the measurement results.

If very heavy contamination occurs at the station due to algae, mud, vegetation or sediment, the pressure probe should be checked from time to time. For example, imprecise or implausible measured values may indicate a "blocked" measuring cell. If necessary, the pressure probe can be cleaned easily.

How to clean the pressure probe

- Uninstall OTT PLS (see Chapter 5).
- Remove the black protective cap.
- Clean the measuring cell carefully using a brush (hard bristles). Lime scale deposits can be removed using a common household scale remover. Make sure to follow the use and safety instructions of the scale remover!
- Rinse the pressure probe **thoroughly** with clear water!
- Reattach the black protective cap.
- Reinstall OTT PLS (see Chapter 5).
- Specifying measured values, comparing with a reference value (staff gauge, contact gauge) and correcting as necessary (enter reference or offset value or via scaling function of the datalogger attached).

Fig. 8: Cleaning the pressure probe.

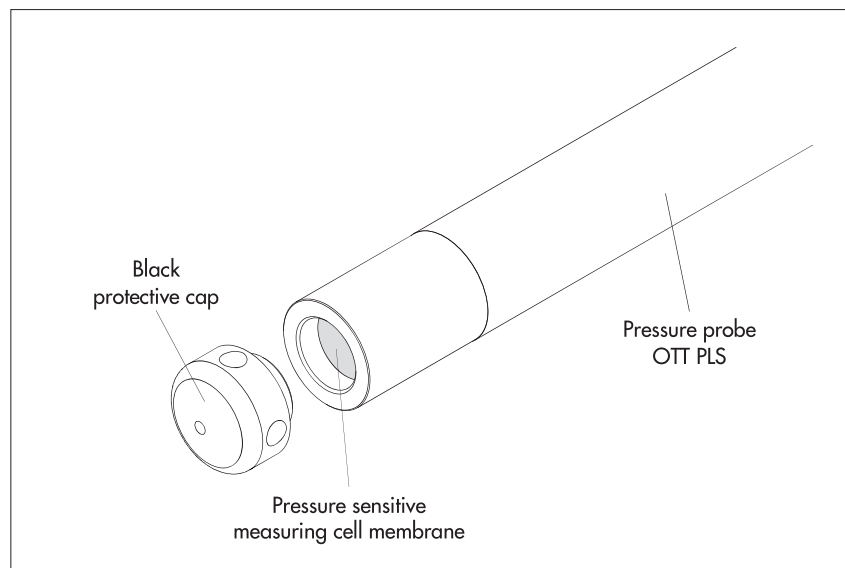

8 Searching for disruptions/troubleshooting

Sensor does not respond to the SDI-12 interface

- ▶ Sensor correctly connected to a datalogger with SDI-12 input (master)?
→ Correct connection assignment.
- ▶ Polarity of the supply voltage reversed?
→ Correct connection assignment.
- ▶ Supply voltage < 9.6 V or > 28 V?
→ Adjust level of voltage supplied (check the length and cross-section of the connection cable).
- ▶ Is the supply voltage not direct current?
→ Only operate sensor with direct current.
- ▶ Does the sensor address of the OTT PLS correspond with the sensor address that the datalogger uses?
→ Correct sensor address.

4 ... 20 mA loop current is missing

- ▶ Is the sensor correctly connected to a datalogger or peripheral device with 4 ... 20 mA input (check polarity)?
→ Correct connection assignment.
- ▶ Is the 4 .. 20 mA loop current correctly supplied through datalogger or OTT PLS (internal/external supply)?
→ Correct connection assignment.

Measured value varies or is not present

- ▶ Sensor dirty?
→ Clean sensor carefully. See Chapter 7, "Carrying out maintenance work".
- ▶ Installation of the sensor steady (e.g. movement from swell)?
→ Optimize installation.
- ▶ Drops of water in the pressure compensation capillary?
→ Replace pressure probe.

Status output at the 4 ... 20 mA interface

The OTT PLS with 4 ... 20 mA interface indicates the operational state or any faults that might occur via the loop current:

Loop current	Status
4 ... 20 mA	correct
3.4 mA	FLASH memory defective
3.3 mA	Watchdog error
3.2 mA	Failed memory
3.1 mA	Pressure cell defective
3.0 mA	Analog converter defective
<3.0 mA	Loop current error: broken line, loop supply missing
3.6 mA	Measurement range not reached (underflow) or global error
3.8 ... <4.0 mA	Marginally below measurement range: The pressure probe delivers an output signal proportional to the water level, but is outside the specification (under range)
>20.0 ... 20.5 mA	Marginally above measurement range: The pressure probe delivers an output signal proportional to the water level, but is outside the specification (over range)
21.0 mA	Measuring range exceeded (overflow)

Status output at the SDI-12 interface

see SDI-12 command **aM1** !

9 Repair

- With a problem with the device, use Chapter 8, "Error messages/error correction" to see if you can resolve the problem yourself.
- In the case of device defects, please contact the repair center of OTT:

OTT Hydromet GmbH
Repaircenter
Ludwigstrasse 16
87437 Kempten · Germany
Telephone +49 831 5617-433
Fax +49 831 5617-439
repair@ott.com

Caution: Only have a defective OTT PLS checked and repaired by the OTT repair center. Under no circumstances carry out any repairs yourself. Any repairs or attempted repairs carried out by the customer will result in the loss of any guarantee rights.

10 Note about the disposal of old units



Within the member countries of the European Union

In accordance with the European Union guideline 2002/96/EC, OTT takes back old devices within the member countries of the European Union and disposes of them in an appropriate way. The devices concerned by this are marked with the symbol shown here.

- For further information on the return procedure, please contact your local sales contact. You will find the addresses of all sales partners in the internet on "www.ott.com". Please take into consideration also the national implementation of the EU guideline 2002/96/EC of your country.

For all other countries

- Dispose of the OTT PLS properly after taking out of service.
- Observe the regulations valid in your country for the disposal of electronic devices.
- Never put the OTT PLS into the normal household waste.

Materials used

See Chapter 11 "Technical data"

11 Technical Data

Water level

Measuring range	0 ... 4 m water column (0 ... 0.4 bar) 0 ... 10 m water column (0 ... 1 bar) 0 ... 20 m water column (0 ... 2 bar) 0 ... 40 m water column (0 ... 4 bar) 0 ... 100 m water column (0 ... 10 bar)
Resolution (SDI-12 interface)	0.001 m; 0.1 cm; 0.01 ft; 0.1 mbar; 0.001 psi
Accuracy (linearity + hysteresis)	
SDI-12 interface	$\leq \pm 0.05\%$ of full scale
4 ... 20 mA interface	$\leq \pm 0.1\%$ of full scale; 10 ppm/°C at 20 °C
Long-term stability (linearity + hysteresis)	$\leq \pm 0.1\%$ of full scale
Zero point drift	$\leq \pm 0.1\%$ of full scale
Units	m, cm, ft, mbar, psi
Overload protection for the measuring cell (without permanent mechanical damage)	
0 ... 0.4 bar	4 bar
0 ... 1 bar	10 bar
0 ... 2 bar	15 bar
0 ... 4 bar	25 bar
0 ... 10 bar	40 bar
Pressure sensor	ceramic, capacitive; temperature-compensated
Temperature-compensated operating range	-5 °C ... +45 °C

Temperature

Measuring range	-25 °C ... +70 °C
Resolution	0.1 °C
Accuracy	± 0.5 °C
Units	°C, °F
Temperature sensor	NTC
Supply voltage	+9,6 ... +28 V DC, typically 12/24 V DC
Current consumption	
SDI-12 sleep mode	< 600 μ A
SDI-12 active mode	< 3.6 mA
Interfaces	SDI-12 version 1.3 RS-485 (SDI-12 protocol) 4 ... 20 mA; 2-wire (scaleable)
Reaction times	
Boot time	5,000 ms
Measuring time	<2,000 ms
Storage temperature	-40 °C ... +85 °C

Mechanical Data

Dimensions

Pressure probe L x Ø

195 mm x 22 mm

Cable length

1 ... 200 m (with SDI-12 interface:
1 ... 100 m)

Weight

pressure probe

approx. 0.3 kg

Material

Pressure probe housing

POM, stainless steel 1.4539 (904 L),
resistant to sea water

Cable jacket

PUR

Seals

Viton

Separating membrane

ceramic Al_2O_3 ; 96 %

Type of protection

IP 68

Performance classification in accordance with DIN EN ISO 4373

Measurement reliability

Performance class 1

Temperature range

Temperature class 2

Relative humidity

Class 1

EMC limits

complies with EN 61326-1:2013



Appendix A – Connecting the OTT PLS via SDI-12 or RS-485 interface to an OTT netDL or OTT DuoSens datalogger

Method A: Connecting the OTT PLS via the SDI-12 interface (protocol and physical interface: SDI-12). The maximum length of the cable is 100 m.

- Connect the OTT PLS to the OTT netDL IP datalogger or to the OTT DuoSens Compact Datalogger as shown in Figure 9. Also refer to OTT netDL or OTT DuoSens Operating Instructions.

Fig. 9: Connecting the OTT PLS to an OTT netDL or OTT DuoSens using an SDI-12 interface.

The letters above the screw terminal strips identify the connectivity options available on the OTT netDL/OTT DuoSens.

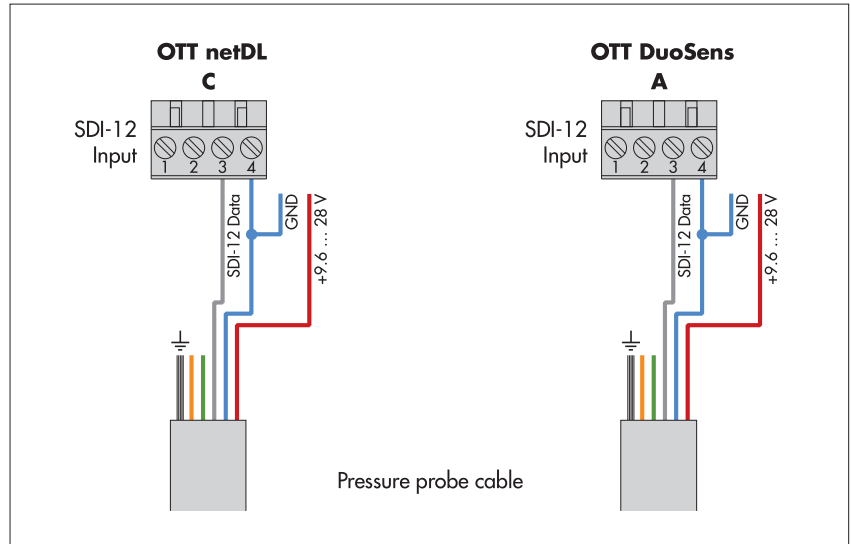

Method B: Connect OTT PLS using the physical RS-485 interface (SDI-12 protocol via physical RS-485 interface). The maximum length of the cable is 1,000 m.

- Connect the OTT PLS to the OTT netDL IP datalogger or to the OTT DuoSens Compact Datalogger as shown in Figure 10. Also refer to OTT netDL or OTT DuoSens Operating Instructions.

Fig. 10: Connecting the OTT PLS to a to an OTT netDL or OTT DuoSens using an RS-485 interface (SDI-12 protocol).

The letters above the screw terminal strips identify the connectivity options available on the OTT netDL/OTT DuoSens.

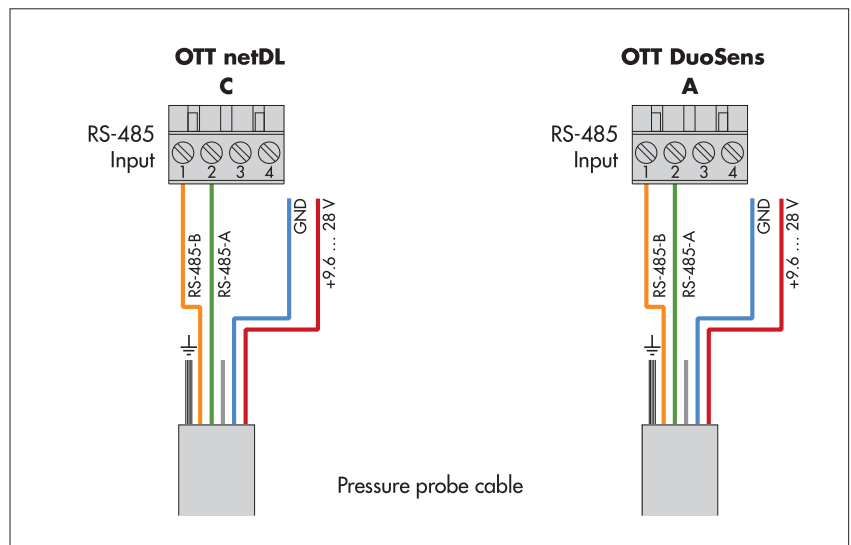

- To achieve better protection against overloads, you can optionally connect the cable shielding to a grounding point/equipotential busbar.

Configuring the OTT netDL/OTT DuoSens for the OTT PLS with SDI-12 interface

- Create an OTT netDL/OTT DuoSens channel with "SDI-12 Master" or "OTT SDI RS485" function block (Serial sensors tab).
- Apply the following settings:

Fig. 11: Setting the operating parameters of the OTT netDL/OTT DuoSens "SDI-12 Master" function block.

The function block "OTT SDI RS485" is set in the same way.

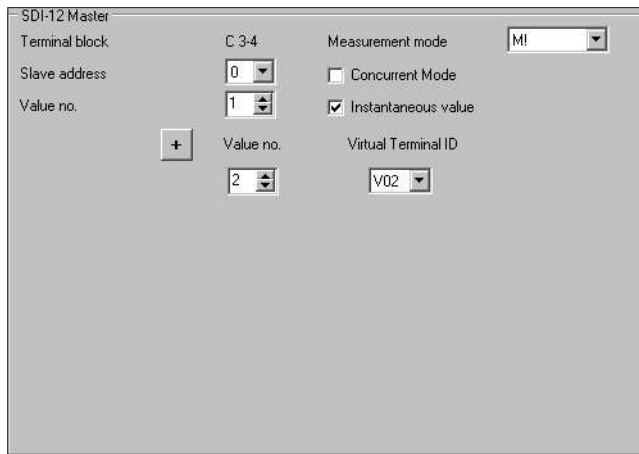

- ▶ Terminal block
 OTT netDL "OTT SDI RS485": C 1-2 (default)
 OTT netDL "SDI-12 Master" C 3-4 (default)
 OTT DuoSens "SDI-12 Master" A 3-4 (default)
 OTT DuoSens "OTT SDI RS485": A 1-2 (default)
 Terminal block (screw terminal strip) of the OTT netDL/OTT DuoSens to which the PLS is connected.
- ▶ Slave address
 SDI-12 bus address. Each slave address may only be allocated once to an SDI-12 bus feed. (Check/set: Use the "OTT SDI-12 Interface" tool of the operating program.)
 Default setting: "0" (only one OTT PLS is connected to the terminal block with no bus operation).
- ▶ Value no.
 Identifies which value the OTT PLS is recording on this channel.
 – In "M!" Measuring Mode: Water level = 1, temperature = 2
 – In "M1!" Measuring Mode: Status of the last measurement = 1
- ▶ Measurement mode
 – "M!" for water level and temperature
 – "M1!" for the status of the last measurement.
- ▶ Concurrent Mode*
: Uses the Concurrent Measuring Mode (C!, C1!) instead of the SDI-12 default Measuring Mode (M!, M1!). This allows simultaneous measurement using multiple sensors connected to a bus line (the sensors respond to a measurement command without service request). The sensors must support version 1.2 or later of the SDI-12-Standard. For further information on the Concurrent Mode, please refer to the SDI-12-Standard (please visit "www.sdi-12.org"). This mode is helpful when multiple sensors are connected to one single bus line and a longer measuring time and the same query interval are used for the sensors.

* only in combination with an OTT netD

- ▶ Instantaneous value* : Upon an instantaneous value request (via LCD display and jog shuttle), the OTT netDL sends a command to the OTT PLS to start a measurement. Until this measurement is complete, the LCD display uses the last measured value (or the instantaneous value last displayed, whichever is most recent). On the display this is identified by an "s" to the right of the channel number (sensor number). After completing the measurement, the new measured value appears without additional identification.
 - : Shows the last measured value of the sensor (measured value of the last query interval) for an instantaneous value request. On the display, this is identified by an "s" to the right of the channel number (sensor number), (also refer to the OTT netDL IP Datalogger Operating Instructions, Chapter 9.1). This setting is helpful for sensors for which a longer measuring period and shorter query interval is used.
- ▶ Value no./ Virtual Terminal ID Allocation of the additional measured value of the OTT PLS which is not recorded in this channel to the virtual terminal (only for the "M!" Measuring Mode; temperature value).
- In the appropriate "Channel" function blocks, set the required units and number of decimal places (m: 3; cm: 0; ft: 2; mbar: 1; psi: 3; °C: 1; °F: 1; Status: 0).

* Only in combination with an OTT netDL

Notes:

- ▶ To record the two measured values of an OTT PLS, two channels in the OTT netDL/OTT DuoSens are therefore required. The first channel contains the "SDI-12 Master" or "OTT SDI RS485" as an input signal. The other channel contains a "Virtual Sensor" function block (V02) as an input signal. Of course, only one single measured value can be recorded. In this case, no entry is required in the "Value no./Virtual terminal ID." box. When the status of the last measurement is to be recorded as well, an additional channel including the "SDI-12 Master" or "OTT SDI RS485" function block and the "M!" Measuring Mode are required.
- ▶ Further information on the SDI-12 commands and responses used can be found in Chapter 6, "SDI-12-commands and responses".
- ▶ The OTT PLS provides the measurement results for retrieval 2 seconds after the SDI-12 commando **aM!**.

Appendix B – Connecting the OTT PLS to an OTT netDL or OTT DuoSens datalogger using a 4 ... 20 mA interface

- Connect the OTT PLS to the OTT netDL IP datalogger or to the OTT DuoSens Compact Datalogger as shown in Figures 12 and 13. Take note of the operating instructions for the OTT netDL/OTT DuoSens. Maximum cable length: dependent on the level of the supply voltage and size of the burden (load resistor). Ensure that the ohmic resistance of the connection cable together with any burden present does not exceed the maximum permitted load resistance (see Chapter 5.7). The upper limit for the cable length is 1,000 m in all cases.

Fig. 12: Connecting the OTT PLS to the OTT netDL using a 4 ... 20 mA interface.

The letters above the screw terminal strip identify the possible connections on the OTT netDL.

The supply for the loop current and the supply of the OTT PLS is made, in the application example shown, directly from the OTT netDL.

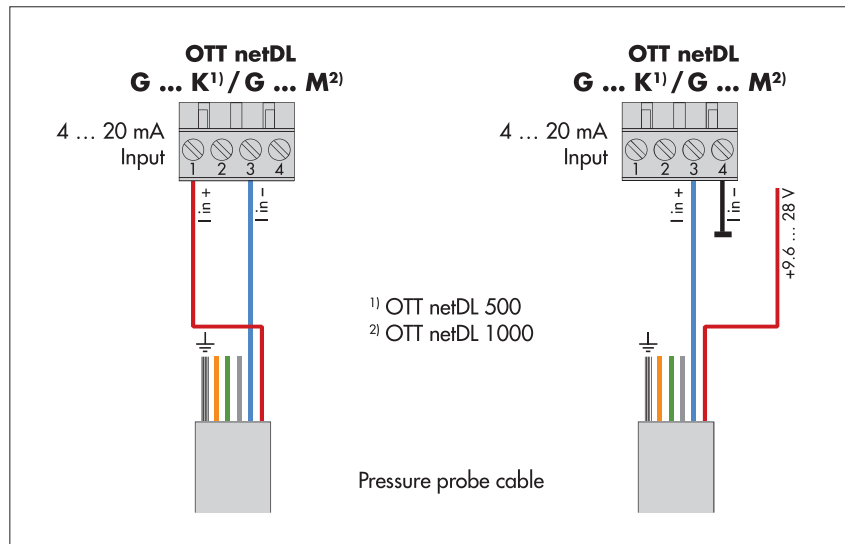
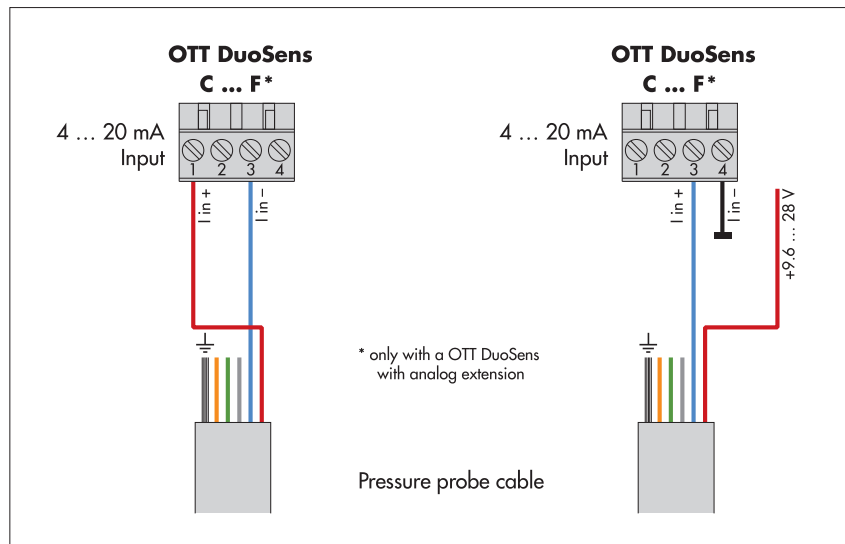

Fig. 13: Connecting the OTT PLS to an OTT DuoSens using a 4 ... 20 mA interface.

The letters above the screw terminal strip identify the possible connections on the OTT DuoSens.

The supply for the current loop and the supply of the OTT PLS is made in the application example shown on the left directly from the OTT DuoSens.



- To achieve better protection against overload, you can optionally attach the cable shielding to a ground point/potential equalization panel.

Configuring OTT netDL/OTT DuoSens for OTT PLS with 4 ... 20 mA interface

- Create an OTT netDL/OTT DuoSens channel with function block "U/I/Pt100/..." ("Analog sensors" tab).
- Apply the following settings:

Fig. 14: Setting operating parameters of the OTT netDL/OTT DuoSens "U/I/Pt100/..." function block.

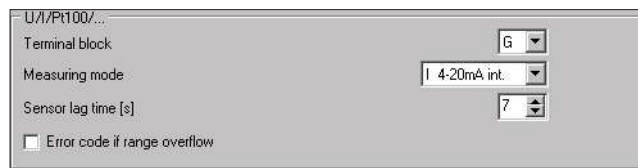

- ▶ Terminal block

OTT netDL 500:	G ... K
OTT netDL 1000:	G ... M
OTT DuoSens:	C ... F

 Terminal block used (screw terminal strip) of the OTT netDL/OTT DuoSens.
- ▶ Measurement mode
 - with internal supply: "I 4-20 mA int."
 - with external supply: "I 4-20 mA ext."
- ▶ Sensor lag time (s)

switches on the OTT netDL/OTT DuoSens input 7 seconds before the actual measurement process
- ▶ Error code if range overflow

If required: record error codes on range overflow

- Insert a "2-point scaling" function block into this channel and set the appropriate water level values for the electrical values measured (e.g. Point 1: 4 → 0; Point 2: 20 → 40) With this function it is possible to reference a level zero at the same time.

Note on Appendices A and B

To reference OTT PLS measured values to a level zero: Enter the contact gauge/staff gauge measurement, for example using the scaling function of the datalogger connected to the OTT PLS (e.g. OTT netDL/OTT DuoSens).

Example:

$$y = ax + b \quad \begin{array}{l} a = 1 \text{ for level measurement and } -1 \text{ for depth measurement} \\ b = \text{reference or offset value} \end{array}$$

Alternatively with SDI-12/RS-485 interface: set a reference value or offset value using the SDI-12 transparent mode of a datalogger when starting up.

Appendix C – Installing the OTT FAD 5 humidity absorbing system

The OTT FAD 5 humidity absorbing system accessory for the OTT PLS pressure probe fulfills various functions:

- ▶ drying the air that has entered the pressure compensation capillary;
- ▶ connecting the pressure probe cable with a connection cable to the data-logger/electrical supply via several two-pin connectors;
- ▶ with short pressure probe cables (< 5 m): it can be used as a fixing point to hang the OTT PLS.

Fig. 15: Installing the OTT FAD 5 humidity absorbing system.
(Housing lid has been removed.)

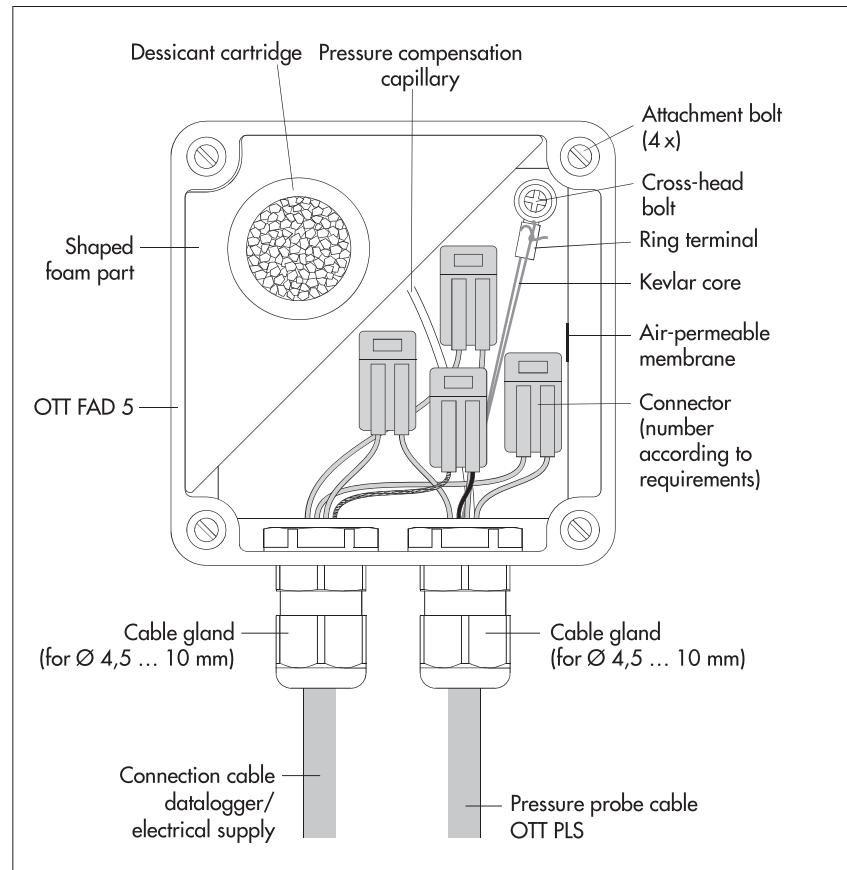

Requirements of the installation location

- ▶ The installation location must be protected from humidity as effectively as possible.
- ▶ If the installation location is in a control cabinet: There must be a pressure compensation possibility to the surroundings (no hermetically sealed closure)!
- ▶ Installation position only as shown in Figure 15.
- ▶ OTT FAD 5 to be used as a fixing point: Attach the humidity absorbing system over the station so that the pressure probe hangs freely (cable length OTT PLS < 5 m).

Fasten the OTT FAD 5 as follows:

- Unscrew the four captive screws on the housing lid and remove it.
- Secure the humidity absorbing system on a solid surface with four screws. Hole spacing: 79 mm. (Select screws appropriate to the material: e.g. wood screws with plugs, machine screws with nuts, Ø 4 mm.)

How to connect the cable to the OTT FAD 5:

Caution:

- ▶ Only remove the transport protection for the pressure probe cable immediately before connecting!
- ▶ Do not damage the pressure compensation capillary, do not block it, and protect it from contamination and humidity!

- Feed the pressure probe cable through a cable gland on the OTT FAD 5.
- Only if the OTT FAD 5 is used as the fixing point for hanging the OTT PLS: secure ring terminal with the Phillips screw and put the pressure probe cable under tension.
- Tighten the cable gland firmly by hand.
- Remove approx. 80 ... 100 mm of the insulation of the datalogger connection cable/electrical supply.
- Feed the connection cable through the second cable gland on the OTT FAD 5 and tighten the cable gland firmly by hand.
- Connect the wires of both cables with each other appropriately: To do this, completely open the connectors (raise orange lever by approx. 90 °), insert wires with 10 mm insulation removed, close lever. Size range 0.08 ... 2.5 mm². Fine-wired conductors do not require end sleeves. For wire allocation, see sticker on the housing lid of the OTT FAD 5.

How to insert the dessicant cartridge and check it:

- Insert the dessicant cartridge into the shaped foam part. The coloured indicator must be orange!
- Immediately replace the housing lid and secure with the four captive screws.
- Check the colour of the coloured indicator at regular intervals. The intervals are heavily dependent on the atmospheric humidity present. Recommendation: after initial installation, check at monthly intervals. Afterwards the intervals can be adapted to the local conditions. Take seasonal climate changes into account.
- Follow the directions on the slip enclosed with the dessicant cartridge to regenerate the dessicant cartridge.

Information on the functional principle of the dessicant cartridges:

The air entering the humidity absorbing system through an air-permeable membrane in the side wall of the OTT FAD 5 is dried by the dessicant cartridge. This prevents humid air from entering the pressure compensation capillary as a result of temperature and air variations. Humidity could block the pressure compensation capillary due to the formation of condensation and lead to inaccurate measurement results.

The dessicant cartridge contains silica gel with a coloured indicator. It has the property of extracting water from the surrounding air and is therefore used for drying air that is contained in a device. Due to the coloured indicator, the silica gel is orange when dry and white when wet. Once the silica gel has become white, it can no longer keep the air dry and must be exchanged for a dessicant cartridge with orange silica gel.

Appendix D – Installing the OTT FAD 4PF humidity absorbing system

The OTT FAD 4PF humidity absorbing system dries the surrounding air that enters the pressure compensation capillary.

- Mount the humidity absorbing system at the driest position possible (e.g. with double-sided tape). If this is in a control cabinet, it is important that there is a pressure compensation possibility to the outside (no hermetically sealed closure!).
- Insert the pressure compensation capillary at least 5 cm into the PVC tube of the humidity absorbing system as shown in Figure 16.

Fig. 16: Installing the OTT FAD 4PF humidity absorbing system.

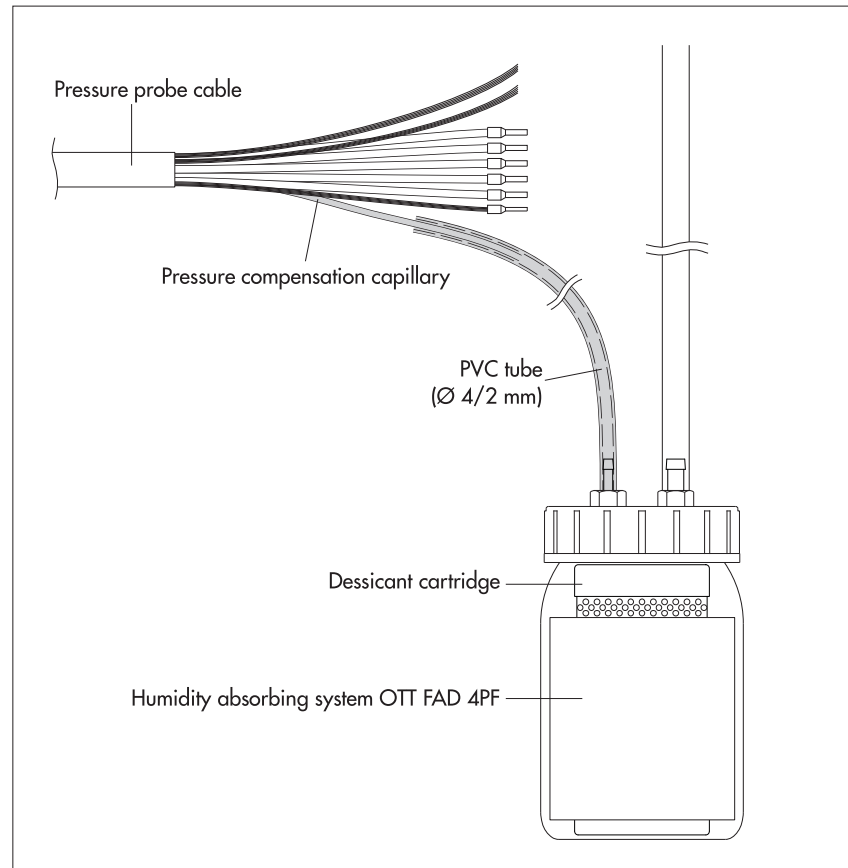

- Please note the instruction leaflet enclosed with the OTT FAD 4PF for regenerating the desiccant cartridge.

Appendix E – Note on Declaration of Conformity

If necessary, you can download the current version of the Declaration of Conformity of the OTT PLS from our website as a PDF file: „www.ott.com/resources“!

Document number
63.037.001.B.E 08-0818



OTT Hydromet GmbH

Ludwigstrasse 16
87437 Kempten · Germany
Phone +49 831 5617-0
Fax +49 831 5617-209

info@ott.com · www.ott.com