

Operating Instructions

Small Current Meter C2

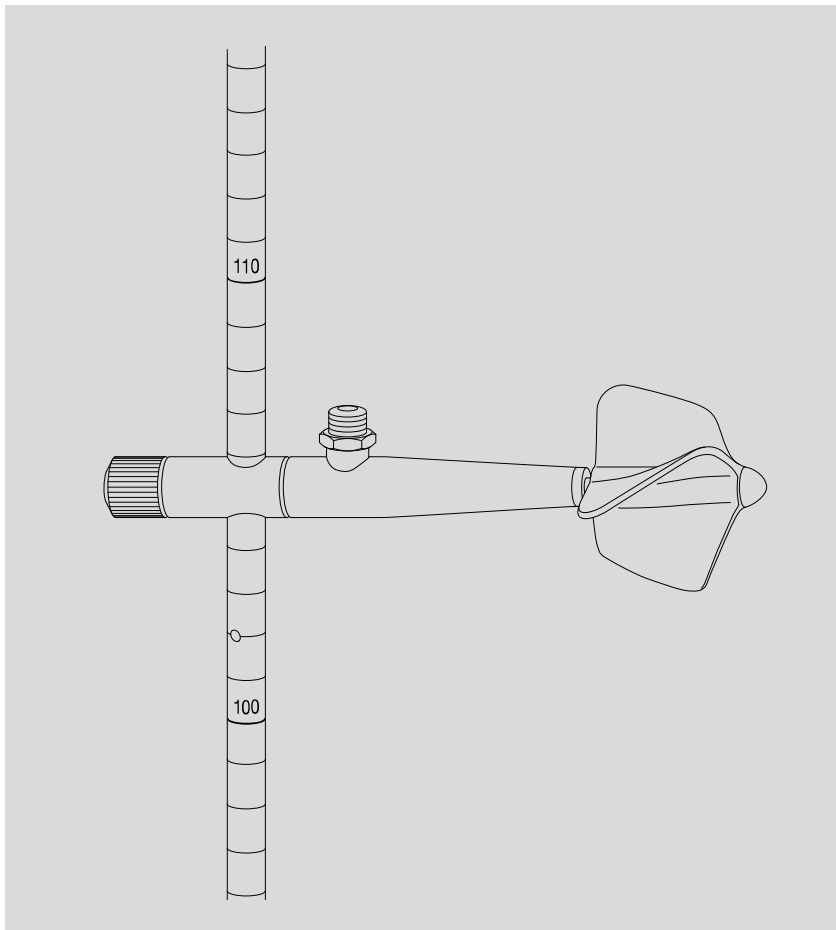

English

We reserve the right to make technical changes!

1. Application

The C 2 Small Current Meter is used if at low water levels (minimum depth of water 4 cm) the flow velocity between 2.5 cm/sec. and 5 m/sec. (only by means of special fixing) has to be measured.

2. Construction (Fig. 1)

- Meter body (1) stream-lined;
material: VA 1.4305
- Clamp (6) for fixing the current meter to 9 mm rod.
- Bearing of spindle by stainless precision ball bearings (15) in oil-filled chamber (31) with capillary seal.

An exchange of the ball bearings is possible without influencing the calibration equation.

- Contact making by magnetically actuated switch. The magnet (27) is incorporated in drum (20). One propeller revolution corresponds to one impulse. The magnetically actuated switch (8) is pressure-tight up to 30 bar.
- Cable connection by screw joint (11).
- Working voltage is 9 V d.c. max. at a max. load of 1.4 W. The counter sets supplied by us meet these requirements.

3. Handling

3.1 C 2 small current meter

The meter body is supplied without oil filling in chamber (31). Before starting measurement for the first time

OTT special oil (26)

has to be filled in as follows (see Fig. 2):

- Screw the complete spindle (2) out of the meter body (1), using wrench (21).
- Fill chamber (31) half-full with oil.
- Screw in again the complete spindle (2).

This oil filling can remain in the meter body for several measurements, if the pauses between the measurements are not longer than 1 week. In case of pauses of more than 1 week it is advisable to remove the oil after measurement. Before starting a new measurement, proceed as described above.

- Slip propeller (28) (corresponding to the measuring range) onto shaft (13).

Propeller No.	Velocity v (m/sec.)		Component wirkung
	min.	max.	
1	0.025	1.0	± 30°
2	0.030	2.0	± 20°
3	0.035	4.0	± 10°
4	0.060	5.0	---
5	0.050	1.0	± 20°
6	0.055	2.0	± 10°

- Attach meter body to rod or relocating device resp. (see point 3.2).
- Connect cable as follows: the cable end with screw joint (11) to meter body; cable end with plug to 9 mm rod, or to handle (30), or to clamping piece (29); the other two plugs to the counter set.
- Check proper functioning by turning the propeller with counter set being switched-on.

3.2 Rod

Depending on order, there are three possibilities:

3.2.1 Rod of 9 mm dia. without relocating device (Fig. 4) (with or without graduation)

- join by screwing two, or better, three rod sections
- attach foot (25)
- slip current meter over the rod and lock it
- fix handle (30) to the upper rod end
- connect cable.

The distance from bottom edge of rod foot to mid-point of propeller can be read at the top edge of the meter body, if the rod is provided with graduation.

3.2.2 Rod of 9 mm dia. with graduation and relocating device (Fig. 5)

- join by screwing three rod sections
- attach foot (25)
- join by screwing both sections of the relocating device (34)
- put meter body into lower section of the relocating device and slip it together with this over the rod. Make sure that clamp (6) is opened.
- fix handle (30) to the upper rod end
- connect cable.

The distance from bottom edge of rod foot to mid-point of propeller plus 1.00 m can be read at the top edge of the relocating device on the graduation of the rod.

3.2.3 Rod of 20 mm dia. with relocating device (Fig. 6)

- fix current meter into clamping piece (29)
- screw clamping piece to relocating device (32) - and ensure that the clamping jaws (33) are opened.
- slip relocating device over the 20 mm rod and lock it
- connect cable.

The distance from bottom edge of base plate to mid-point of propeller plus length of relocating device (e.g. 1 m) can be read at the top edge of the relocating device on the graduation of the rod.

4. Maintenance

4.1 Ball bearings

For cleaning, screw out the spindle as per point 3.1. The ball bearings are cleaned in a cup with pure benzine by jerk movements up and down.

Do not use petroleum or Triol

Exchange of ball bearings is possible by dismantling magnetic drum (20) and circlip (18).

4.2 Electric contact device (8)

The magnetically actuated switch is maintenance-free. Lifetime approx. 1 million switching operations.

In case of faulty measurement, please check, whether

- batteries in the counter set
- cable
- plugs

are defective.

If the magnetically actuated switch has to be exchanged, proceed as follows:

- loosen nut (7)
- screw out magnetically actuated switch (8)
- screw in new magnetically actuated switch
- adjust duty ratio 1:1 with the aid of a counter set with buzzer. For that purpose slip on propeller and turn it by 360°. Contact must be made for 180°; otherwise turn the magnetically actuated switch to another position.
- tighten nut (7).

4.3 Screw joint (Fig. 3)

If the cable connection has to be renewed, proceed as follows:

- cut off cable
- slip knurled nut (11) and duct plug (10) onto the cable (Fig. 3a)
- remove insulation for a length of 6 mm and twist strands of wire together
- slip on tubular rivet (9), press it in 2times with pliers and check to correct seat (Fig. 3b + c)
- slip duct plug over tubular rivet (Fig. 3d).

5. Measuring procedure

- Start operation of current meter as described under point 3 and put it into the measuring point.
- Count propeller revolutions (r) during the pre-set measuring time (t) by means of a counter set.
- Determine speed $n = \frac{r}{t}$
- Calculate water velocity (v) by means of the equation indicated in the calibration certificate BARGO, or read it from the velocity table BAREL.

Example: for propeller No. 3-93173
with the equation
 $v = 0.2520 n + 0.006$ (m/sec.)

$$r = 125$$

$$t = 50 \text{ sec.}$$

$$n = \frac{125}{50} = 2.5 \text{ rps.}$$

$$v = 0.2520 \times 2.5 + 0.006 = 0.636 \text{ m/sec.}$$

Fig. 1

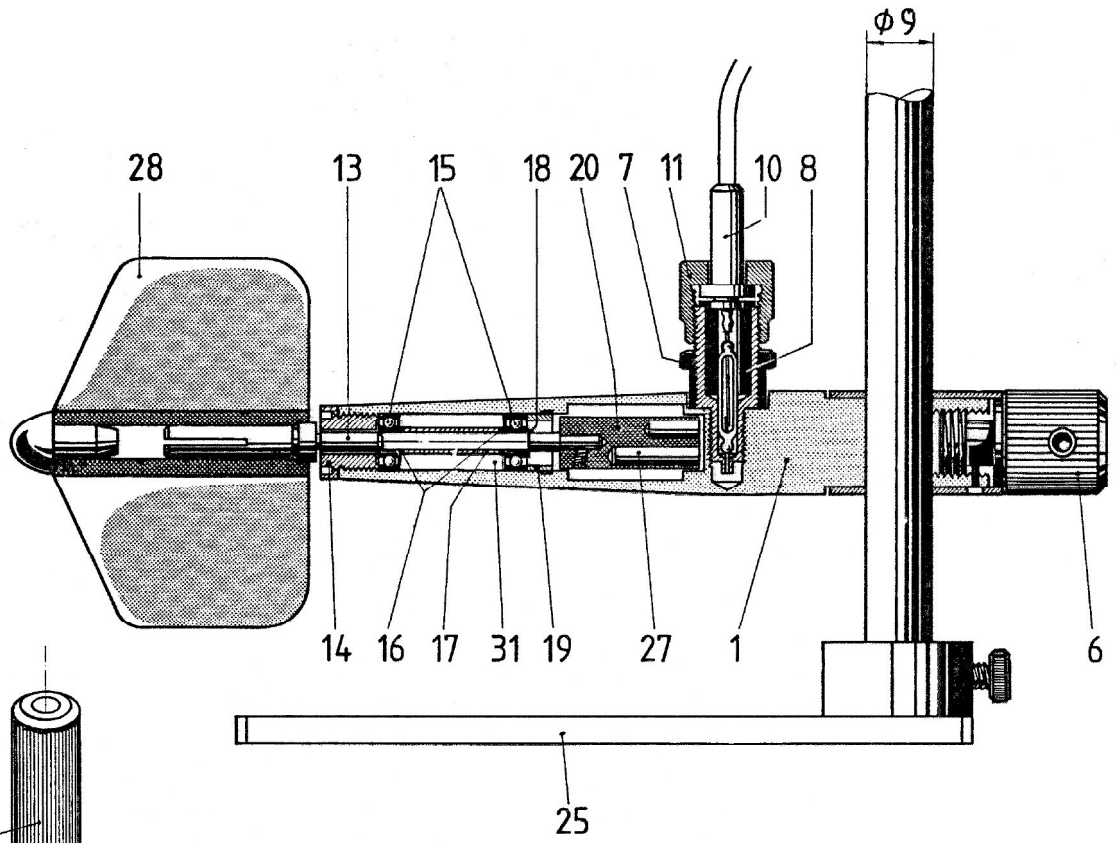

Fig. 2

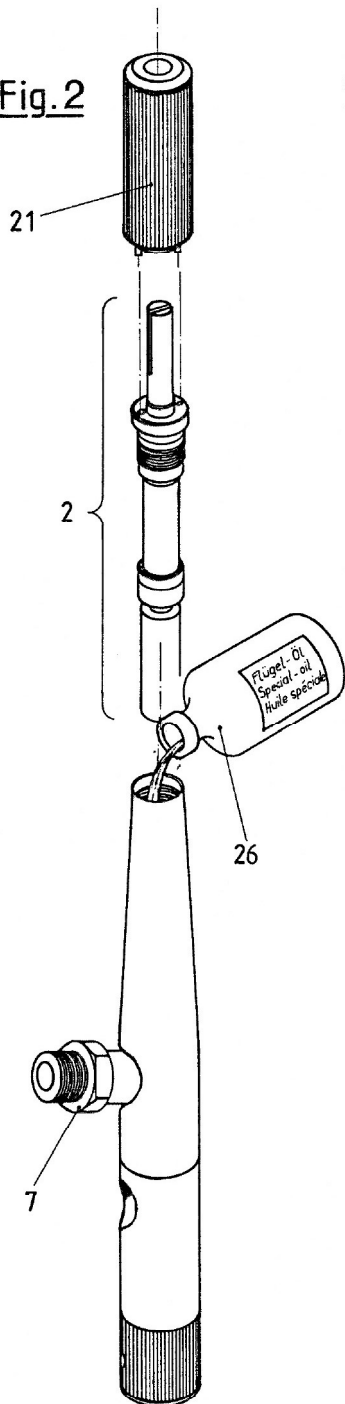
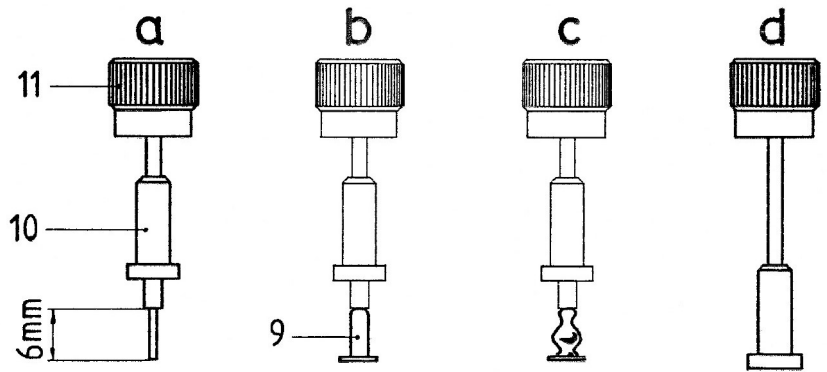
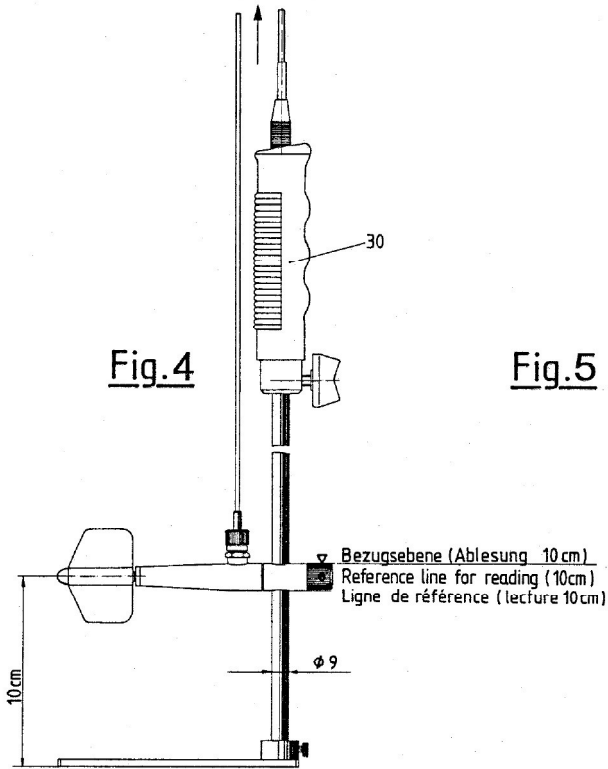

Fig. 3



Zum Zählgerät
to counter set
vers le compteur



Zum Zählgerät
to counter set
vers le compteur

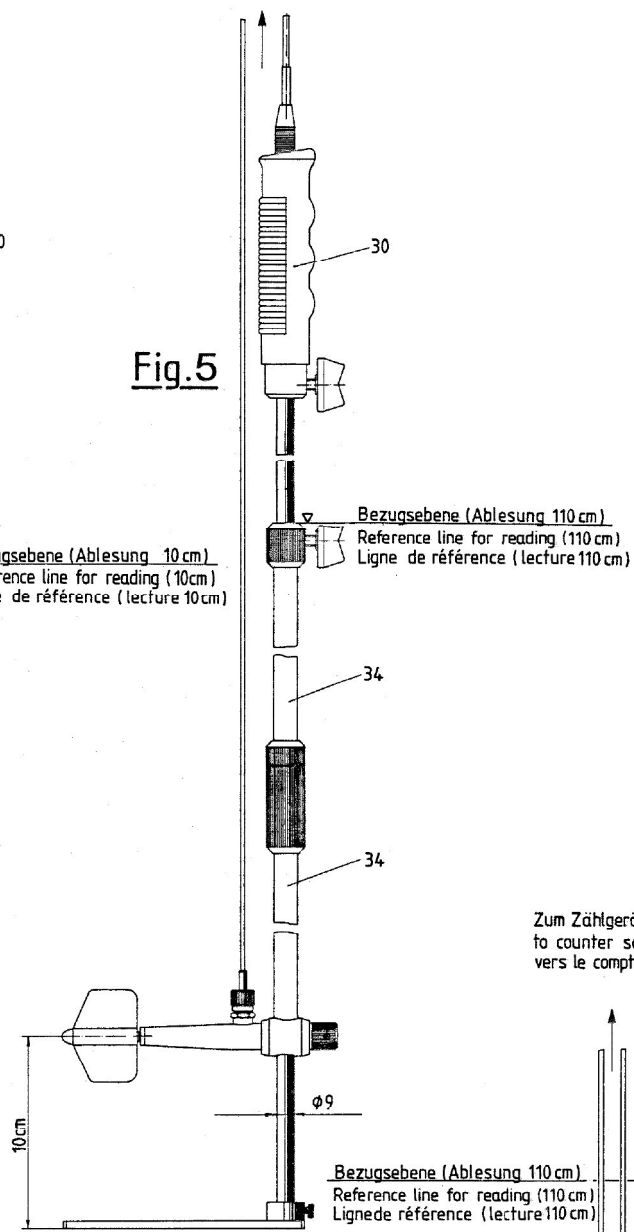

Zum Zählgerät
to counter set
vers le compteur

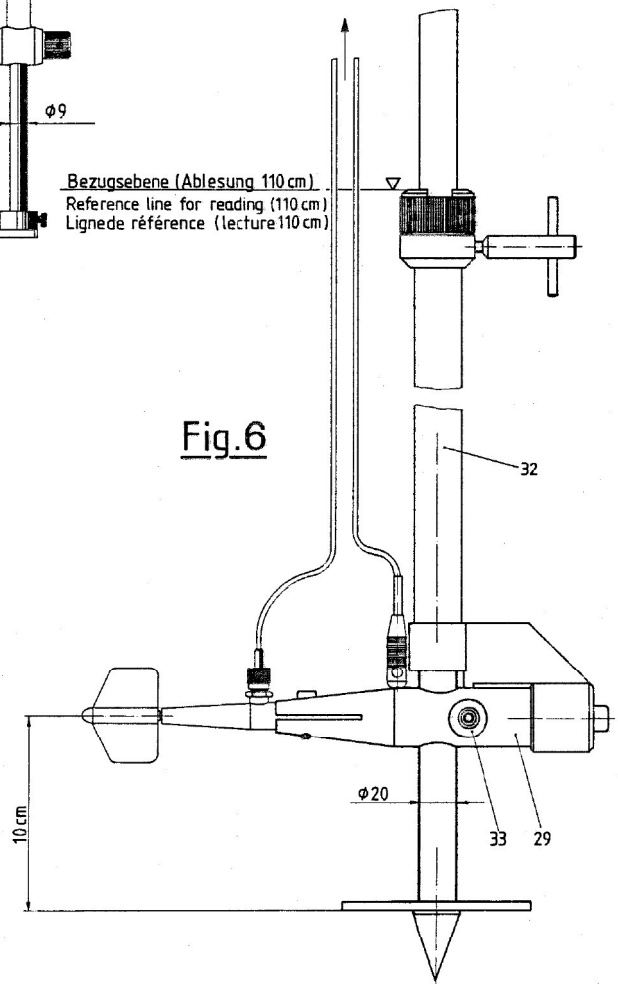

Anströmrichtung
Direction of flow
Sens d'écoulement



Achtung:

Verwenden Sie bei Schaufeln mit 50 mm Durchmesser (Schaufel-Nr. 1 bis 4) einen Distanzring auf der Flügelstange!

Ohne Distanzring streifen diese Schaufeln bei vollständig abgelassenem Flügel an der Bodenplatte → Fehlmessung, Beschädigung.

Please note:

For use with 50 mm diameter propellers (propeller No. 1 – 4) a spacer ring located at the base of the rod is required!

Without this spacer ring the propellers come into contact with the base plate when the meter is lowered to the lowest position → leading to faulty measurement and potential damage.

Attention:

Veillez ajouter sur la perche une bague de sécurité si vous utilisez une hélice de diamètre 50 mm (hélices N° 1 à 4).

Sans bague de sécurité, ces hélices frottent contre le pied de la perche quand le moulinet est en position basse → erreur de mesure, dommage.

Atención:

Utilice con hélices de 50 mm de diámetro (hélice N° 1 a 4) un anillo de separación en la barra del molinete!

Sin anillo de separación estas hélices rozan en la base de fijación al bajar completamente el molinete lo cual genera → errores de medición y daños.

Ergänzung zu Fig. 4 und Fig. 5
Supplement to Fig. 4 and Fig. 5
Annexe aux Fig. 4 et Fig. 5
Anexo a Fig. 4 y Fig. 5

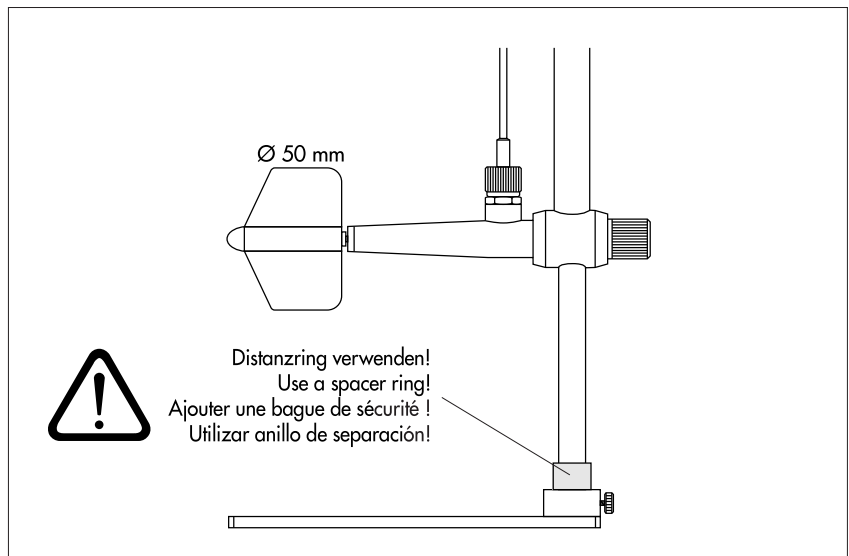

Document number
10.150.005.B.E 05-0811

OTT Hydromet GmbH

Ludwigstrasse 16
87437 Kempten · Germany
Tel. +49 8 31 56 17-0
Fax +49 8 31 56 17-2 09

info@ott.com
www.ott.com